

Dwyer

SERIES OP, PE & TE

ORIFICE PLATE FLOWMETERS

PVC or PTFE, Liquid and Gas Use Options

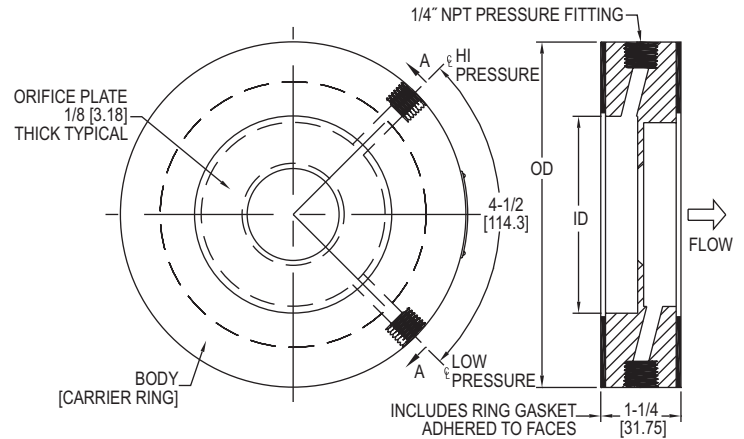

The **Series OP Orifice Plate Flowmeters** are a complete flow metering package. They incorporate a stainless steel orifice plate with a unique holder or carrier ring containing metering taps and integral gaskets. The Series OP is available in line sizes from 1/2" to 24" and can be used with compatible liquids and gases.

FEATURES/BENEFITS

- Mounted with standard flanges with no need of specialty flanges
- Reduced installation costs with simple installation by slipping the unit between standard flanges
- Easy access with corner type metering taps
- Long operation life with corrosion free material
- Stainless steel wetted parts assures long term reliability and accuracy
- Proven through a wide range of applications for energy efficiency

APPLICATIONS

- Fluid flow rates in building water lines
- Boiler feedwater
- Cooling water
- Combustion or compressed air
- Steam flow

The **SERIES PE & TE Orifice Plate Flowmeters** are two series of plastic orifice plate flow metering packages incorporating a unique holder or carrier ring containing metering taps and integral gaskets. They can be used in place of other primary differential products for efficiency and cost effectiveness.

The Series PE orifice plate flowmeter is of PVC construction and is available in line sizes from 1/2" to 24". This series can be used for air and most gases and meets or exceeds ASME, AGA & ISO standards.

The Series TE orifice plate flowmeter is of PTFE construction and is available in line sizes from 1/2" to 24". This Series can be used with gases, liquids, corrosive and high temperature fluids.

FEATURES/BENEFITS

- Mounted with standard flanges with no need of specialty flanges
- Reduced installation costs with simple installation by slipping the unit between standard flanges
- Easy access with corner type metering taps
- Long operation life with corrosion free material
- Proven through a wide range of applications for energy efficiency
- PTFE construction yields excellent chemical and weather resistance
- TE models are flame retardant without factory gaskets
- Low friction leading to minimum wear and long operation life

APPLICATIONS

- Fluid flow rates in building water lines
- Boiler feedwater
- Cooling water
- Combustion or compressed air
- Steam flow

SPECIFICATIONS

Service: OP & TE: Compatible liquids and gases; PE: Clean air and compatible gases.

Wetted Material: OP: 304 SS, Buna-N gaskets; PE: Gray PVC, Buna-N gaskets; TE: PTFE, Buna-N gaskets.

Accuracy: 0.6% FS. (Beta = .2-.6) $\pm 0.7\%$ for Beta greater than .6.

Temperature Limits: OP: -50 to 200°F (-45 to 93°C); PE: 140°F (60°C) max; TE: -40 to 200°F (-40 to 93.3°C).

Pressure Limits: OP: Limited only by pipe and flange rating restrictions.

Head Loss: 1-Beta ratio² eg: 1-0.72 = 1-0.49 = 51% of the d.p.

Line Sizes: 1/2" to 24".

Process Connection: 1/4" female NPT.

Installation: Standard flange. OP: Any rating (orifice flanges not required); PE & TE: 125#/150# rating.

Pipe Requirements: General requirements 10 diameter upstream and 5 diameter downstream of orifice plate.

Weight: Varies with line size. See chart.

ORIFICE PLATE FLOWMETERS

PVC or PTFE, Liquid and Gas use Options

SERIES OP ORIFICE PLATE FLOWMETER – CAPACITY STRUCTURE

- Material 304/304 L, gaskets Buna-N
- Based on 70°F, 14.7 psia (base conditions)
- Beta value based on std sch pipe I.D.
- 1.25" overall thickness
- Orifice plate thickness is 0.125"

SERIES PE ORIFICE PLATE FLOWMETER – AIR CAPACITY STRUCTURE

- Material PVC, gaskets Buna-N
- Based on 70°F, 14.7 psia (base conditions)
- Beta value based on std sch pipe I.D.
- 1.25" overall thickness
- Orifice plate thickness is 0.125"

SERIES TE ORIFICE PLATE FLOWMETER – CAPACITY STRUCTURE

- Material PTFE, gaskets Buna-N
- Based on 70°F, 14.7 psia (base conditions)
- Beta value based on std sch pipe I.D.
- 1.25" overall thickness
- Orifice plate thickness is 0.250"

MODEL CHART														
OP Model	OP Weight (lb)	PE Model	PE Weight (lb)	TE Model	TE Weight (lb)	Line Size	Bore	Beta	Water Capacity		Air Capacity - Flow in SCFM			
									in d.p. w.c.	Flow in GPM	in d.p. w.c.	at 14.7 psia (0 psig)	at 20 psig	at 100 psig
OP-A-1	1.00	PE-A-1	1.00	TE-A-1	1.00	1/2"	0.200"	0.32	20	0.62	20	2.35	3.63	6.61
OP-A-2	1.00	PE-A-2	1.00	TE-A-2	1.00	1/2"	0.310"	0.50	100	3.44	100	12.21	19.58	36.37
OP-A-3	1.00	PE-A-3	1.00	TE-A-3	1.00	1/2"	0.430"	0.69	320	13.00	200	32.77	56.15	107.47
OP-B-1	1.00	PE-B-1	1.00	TE-B-1	1.00	3/4"	0.250"	0.30	20	0.97	20	3.65	5.66	10.3
OP-B-2	1.00	PE-B-2	1.00	TE-B-2	1.00	3/4"	0.400"	0.49	100	5.69	100	20.21	32.44	60.26
OP-B-3	1.00	PE-B-3	1.00	TE-B-3	1.00	3/4"	0.580"	0.70	320	23.82	200	59.92	102.91	197.2
OP-C-1	2.00	PE-C-1	1.00	TE-C-1	1.00	1"	0.300"	0.29	20	1.38	20	5.24	8.11	14.8
OP-C-2	2.00	PE-C-2	1.00	TE-C-2	1.00	1"	0.520"	0.49	100	9.63	100	34.2	54.92	102.09
OP-C-3	2.00	PE-C-3	1.00	TE-C-3	1.00	1"	0.720"	0.69	320	36.15	200	91.28	156.51	300
OP-D-1	2.00	PE-D-1	1.00	TE-D-1	1.00	1.25"	0.400"	0.29	20	2.46	20	9.31	14.41	26.3
OP-D-2	2.00	PE-D-2	1.00	TE-D-2	1.00	1.25"	0.700"	0.51	100	17.48	100	62.09	99.75	185.5
OP-D-3	2.00	PE-D-3	1.00	TE-D-3	1.00	1.25"	1.00"	0.72	320	71.77	200	180	309.97	595.2
OP-E-1	2.00	PE-E-1	2.00	TE-E-1	2.00	1.5"	0.500"	0.31	20	3.85	20	14.57	22.55	41.16
OP-E-2	2.00	PE-E-2	2.00	TE-E-2	2.00	1.5"	0.800"	0.50	100	22.73	100	80.82	129.68	241.5
OP-E-3	2.00	PE-E-3	2.00	TE-E-3	2.00	1.5"	1.100"	0.68	320	83.95	200	212.18	363.93	697.39
OP-F-1	3.00	PE-F-1	2.00	TE-F-1	2.00	2"	0.600"	0.29	20	5.52	20	20.92	32.38	59.13
OP-F-2	3.00	PE-F-2	2.00	TE-F-2	2.00	2"	1.000"	0.48	100	35.34	100	125.74	202.03	375.8
OP-F-3	3.00	PE-F-3	2.00	TE-F-3	2.00	2"	1.450"	0.70	320	147.74	200	372.09	639.87	1227.63
OP-G-1	4.00	PE-G-1	2.00	TE-G-1	2.00	2.5"	0.750"	0.30	20	8.63	20	32.71	50.64	92.48
OP-G-2	4.00	PE-G-2	2.00	TE-G-2	2.00	2.5"	1.250"	0.50	100	55.54	100	197.54	317.58	590.91
OP-G-3	4.00	PE-G-3	2.00	TE-G-3	2.00	2.5"	1.750"	0.70	320	216.30	200	543.99	936.56	1798.86
OP-H-1	5.00	PE-H-1	2.00	TE-H-1	2.00	3"	0.920"	0.30	20	12.97	20	49.17	76.13	139.06
OP-H-2	5.00	PE-H-2	2.00	TE-H-2	2.00	3"	1.500"	0.49	100	79.94	100	282.9	454.77	846.21
OP-H-3	5.00	PE-H-3	2.00	TE-H-3	2.00	3"	2.150"	0.70	320	324.16	200	816.7	1404.95	2696.28
OP-J-1	7.00	PE-J-1	3.00	TE-J-1	3.00	4"	1.200"	0.30	20	22.03	20	83.58	129.44	236.48
OP-J-2	7.00	PE-J-2	3.00	TE-J-2	3.00	4"	2.000"	0.50	100	141.51	100	503.76	810.06	1507.64
OP-J-3	7.00	PE-J-3	3.00	TE-J-3	3.00	4"	2.800"	0.70	320	547.11	200	1380.03	2373.02	4553.68
OP-K-1	8.00	PE-K-1	3.00	TE-K-1	4.00	5"	1.500"	0.30	20	34.39	20	130.48	202.11	369.29
OP-K-2	8.00	PE-K-2	3.00	TE-K-2	4.00	5"	2.500"	0.50	100	220.80	100	786.23	1264.42	2353.51
OP-K-3	8.00	PE-K-3	3.00	TE-K-3	4.00	5"	3.500"	0.69	320	853.09	200	2152.83	3701.57	7103.22
OP-L-1	10.00	PE-L-1	4.00	TE-L-1	4.00	6"	1.800"	0.30	20	49.46	20	187.86	291	531.75
OP-L-2	10.00	PE-L-2	4.00	TE-L-2	4.00	6"	3.000"	0.49	100	317.74	100	1331.63	1820.05	3387.93
OP-L-3	10.00	PE-L-3	4.00	TE-L-3	4.00	6"	4.200"	0.69	320	1226.98	200	3097.20	5325.20	10219.28
OP-M-1	14.00	PE-M-1	5.00	TE-M-1	6.00	8"	2.400"	0.30	20	87.95	20	333.87	517.25	945.28
OP-M-2	14.00	PE-M-2	5.00	TE-M-2	6.00	8"	4.000"	0.50	100	565.77	100	2014.95	3241.45	6034.85
OP-M-3	14.00	PE-M-3	5.00	TE-M-3	6.00	8"	5.600"	0.70	320	2195.86	200	5532.00	9525.43	18290.00
OP-N-1	20.00	PE-N-1	6.00	TE-N-1	8.00	10"	3.000"	0.30	20	137.35	20	521.58	808	1476.77
OP-N-2	20.00	PE-N-2	6.00	TE-N-2	8.00	10"	5.000"	0.50	100	883.04	100	3145.50	5060.38	9421.74
OP-N-3	20.00	PE-N-3	6.00	TE-N-3	8.00	10"	7.000"	0.70	320	3421.26	200	8626.42	14846.80	28506.17
OP-O-1	30.00	PE-O-1	7.00	TE-O-1	10.00	12"	3.600"	0.30	20	197.73	20	750.9	1163.44	2126.47
OP-O-2	30.00	PE-O-2	7.00	TE-O-2	10.00	12"	6.000"	0.50	100	1271.62	100	4530	7288.16	13570.33
OP-O-3	30.00	PE-O-3	7.00	TE-O-3	10.00	12"	8.400"	0.70	320	4930.86	200	12430.00	21397.00	41089.02
OP-P-1	40.00	PE-P-1	9.00	TE-P-1	15.00	14"	4.000"	0.30	20	244.14	20	927.14	1436.59	2625.81
OP-P-2	40.00	PE-P-2	9.00	TE-P-2	15.00	14"	6.600"	0.50	100	1537.49	100	6477.67	8812.87	16409.42
OP-P-3	40.00	PE-P-3	9.00	TE-P-3	15.00	14"	9.300"	0.70	320	6052.57	200	15251.50	28262.66	50427.78
OP-Q-1	48.00	PE-Q-1	10.00	TE-Q-1	18.00	16"	4.500"	0.30	20	308.76	20	1172.63	1817.05	3321.32
OP-Q-2	48.00	PE-Q-2	10.00	TE-Q-2	18.00	16"	7.600"	0.50	100	2038.95	100	7264.58	11688.26	21764.08
OP-Q-3	48.00	PE-Q-3	10.00	TE-Q-3	18.00	16"	10.700"	0.70	320	8007.74	200	20179.85	34749.32	66737.64

Note: Differential pressure values should be less than 50% of the inlet absolute pressure.